

Features

- Universal AC input (85-264VAC)
- Long 7 year warranty
- Protections: SCP, OVP, OCP, OTP
- 100% full load burn-in test
- DC OK indicator LED with relay contacts
- cooling by free air convection, 5000m operation
- UL, CSA & CE certified with CB report

DIN Rail Series



REDIN45

45 Watt
DIN-Rail
Power Supply



Description

This DIN-rail mounted power supply uses high reliability components to give a long, trouble-free life. The power supply can be end mounted to save space or side mounted for use in low-profile cabinets. Relay contacts simplify DC OK monitoring and the units can deliver 60W start-up power. The REDIN series is fully certified for industrial use and carries a 7-year warranty.

Selection Guide

Part Number	Input Voltage Range [VAC]	Output Voltage [VDC]	Output Trimming Voltage [VDC]	Rated Current [A]	Efficiency typ. [%]	Max. Capacitive Load [μF]
REDIN45-12	85-264	12	12-15	3.75	85	18800
REDIN45-24	85-264	24	24-28	1.875	86	4700

Specifications (measured at Ta= 25°C, 230VAC, full load and after warm up)

BASIC CHARACTERISTICS				
Parameter	Condition	Min.	Typ.	Max.
Input Voltage Range	all operating conditions	85VAC		264VAC
max. Input Voltage	max. 1 second			300VAC 375VDC
Output Voltage Adjustment (Factory Setting) ⁽¹⁾	12Vout 24Vout		12-15VDC (12V±5%) 24-28VDC (24V±5%)	
Input Current	full load, 115VAC full load, 230VAC			1.35A 0.75A
Inrush Current	cold start at 25°C, 115VAC cold start at 25°C, 230VAC			40A 60A
No Load Power Consumption	standard (with Relay) /NR option (no Relay)			<1000mW <500mW
Start Up time	cold start, 230VAC		500ms	1000ms
Rise time	cold start, 230VAC		20ms	
Hold-up time	full load, 115VAC full load, 230VAC		20ms 50ms	
Input Frequency Range		47Hz		63Hz
Operating Frequency Range			65kHz	
Efficiency		see Selection Guide		
Output Ripple and Noise ⁽²⁾	12Vout 24Vout		60mVp-p 75mVp-p	
Over Load Capability	all operating conditions		140% for 5 seconds max.	
Notes:				
Note1: For more details refer to Vadj. Derating Graph on page PA-2				
Note2: Ripple and Noise are measured at 20MHz bandwidth by using a 12" twisted pair-wire terminated with 0.1μF & 47μF parallel capacitor				
continued on next page				



CB-Report
UL60950-1 certified
UL508 certified
IEC60950-1 certified
EN60715 compliant
EN50022 compliant
CSA C22.2 No. 60950-1-07 certified

Specifications (measured at $T_a = 25^\circ\text{C}$, 230VAC, full load and after warm up)

Efficiency vs. Load

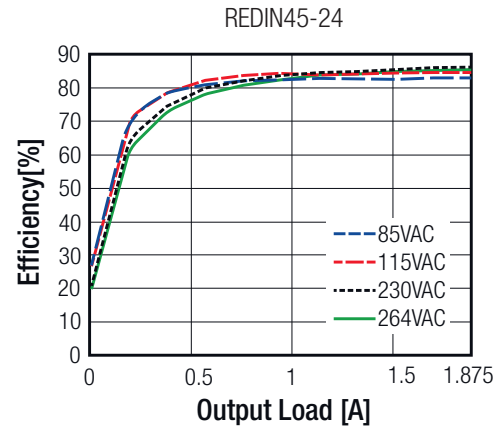
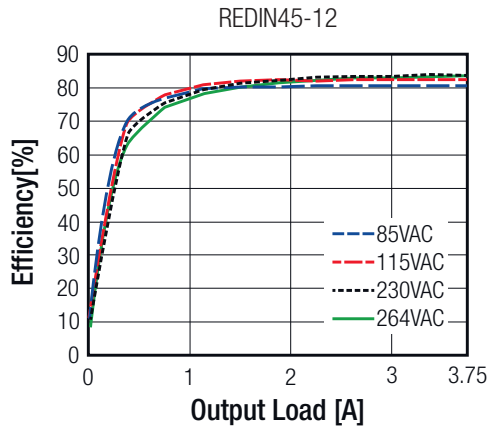

V_{adj.} Derating

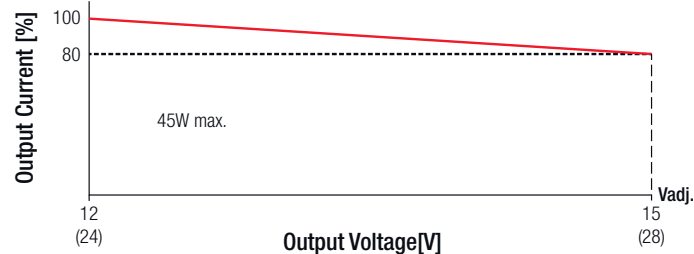

REGULATION

Parameter	Condition	Value
Line Regulation		± 0.1 typ. / $\pm 1\%$ max.
Load Regulation		± 0.1 typ. / $\pm 1\%$ max.
Transient Response ⁽³⁾	12Vout (step load change: 1.875A - 3.75A) 24Vout (step load change: 0.937A - 1.875A)	$\pm 5\%$ typ. $\pm 5\%$ typ.
Dwell Time		100Hz & 1kHz 50% duty
Slew Rate		0.5A / μs

Notes:

Note3: Transient Response + E-CAP loading 3300 μF . Other specs with resistive load only

PROTECTION

Parameter	Condition		Value
Input Fuse			T2.5A, slow blow type
Short Circuit Protection (SCP)			auto-recovery after fault condition, Hiccup Mode
Over Voltage Protection (OVP)	12Vout 24Vout		18VDC max., shut-down latch-off o/p voltage, re-power on to recover 35VDC max., shut-down latch-off o/p voltage, re-power on to recover
Over Voltage Category			OVCII
Over Current Protection (OCP)			150% typ., auto-recovery after fault condition
Over Temperature Protection (OTP)	detect on inside ambient		105 $^\circ\text{C} \pm 5\%$, shut-down latch-off o/p voltage, re-power on to recover
Isolation Voltage	tested for 1 minute	I/P to O/P I/P to FG O/P to FG	3.75kVAC 1.88kVAC 0.5kVAC
Isolation Resistance	500VDC, 70% RH, I/P to O/P; I/P to FG; O/P to FG		100M Ω min.
Leakage Current	240VAC		<1.0mA
Power OK LED	Relay Contacts LED/Relay		1A, 30VDC / 120VAC ON if Vout = 11-16V (12V) / 22-30V (24V)

Specifications (measured at $T_a = 25^\circ\text{C}$, 230VAC, full load and after warm up)

ENVIRONMENTAL

Parameter	Condition	Value
Operating Temperature Range	with derating	-20°C to +70°C (see graph)
Operating Humidity	non-condensing	20% - 90%RH
Vibration		10-500Hz 2G, 60min.
Shock	3 times each axis	10G / 11ms, along X, Y and Z axis
Altitude	see derating graph	5000m
MTBF (+25°C)	according to MIL-HDBK-217F, 115VAC, 60Hz, 75% load	200 x 10 ³ hours
Design Lifetime (+40°C)		87.6 x 10 ³ hours

Derating Graph

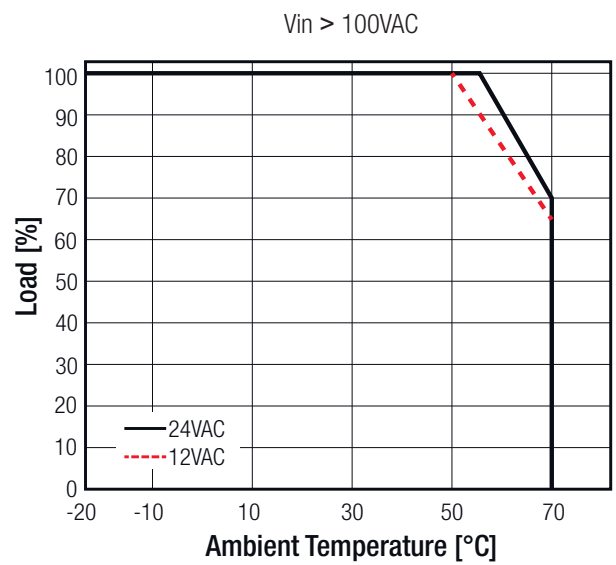
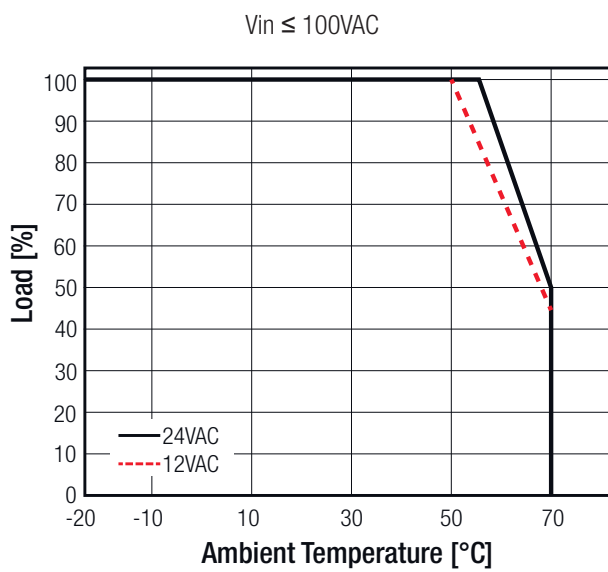

Typical Characteristics

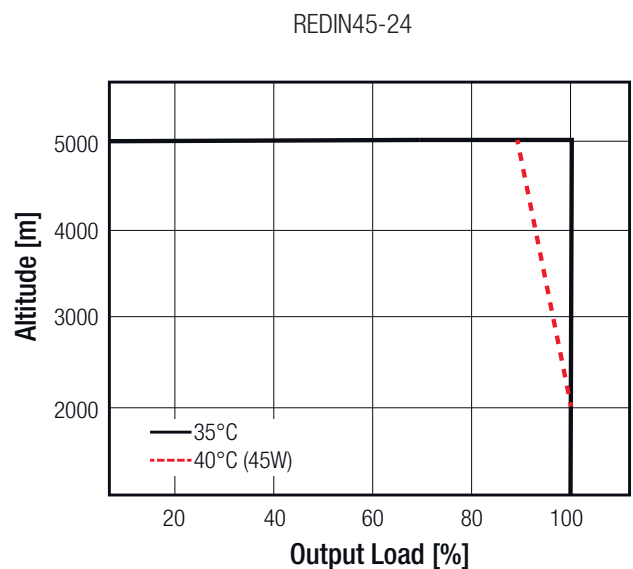
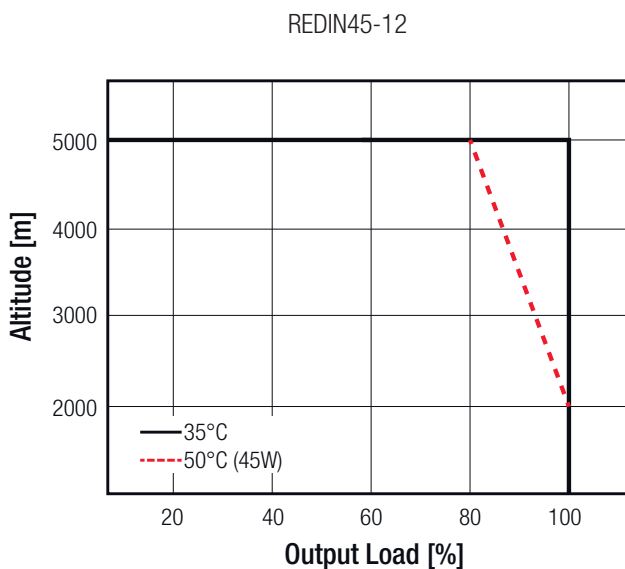

Specifications (measured at $T_a = 25^\circ\text{C}$, 230VAC, full load and after warm up)

SAFETY AND CERTIFICATIONS		
Certificate Type (Safety)	Report / File Number	Standard
UL General Safety	E224736	UL60950-1, 2nd Edition
CSA General Safety		UL1310 C22.2 No. 60950-1-07, 2nd Edition
Industrial Control Equipment General Use Power Supplies	E470721	UL508 C22.2 No. 107.1
IEC/EN General Safety	E224736	IEC/EN60950-1, 2nd Edition
Chinese Safety Standard	E224736	GB 4943.1-2011
EAC	RU-AT.37.02367	TP TC 004/2011
RoHs2		RoHs 2011/65/EU
EMC Compliance		
EMC Compliance	Report / Condition	Standard / Criterion
EMI Standard	Report: HA150146	EN55022, Class B EN55024, Class B FCC15, Class B
ESD	±8kV Contact & Air Discharge 10V/m, 80-3000MHz, 80% AM at 1kHz Level 2	EN61000-4-2, Criteria A
Radiated Immunity		EN61000-4-3, Criteria A
Fast Transient	±2kV / L-N, ±4kV / L, N-FG 10Vrms, 0.15-80MHz, 80% AM at 1kHz	EN61000-4-4, Criteria A
Surge		EN61000-4-5, Criteria A
Conducted Immunity	40% reduction, 200ms 70% reduction, 500ms 90% reduction, 5s	EN61000-4-6, Criteria A
Power frequency magnetic field immunity test		EN61000-4-8, Criteria A
Noise Immunity	not applicable input below 75W	EN61000-4-11, Criteria A
Harmonic Immunity		EN61000-4-11, Criteria B
Voltage Flicker		EN61000-3-2 EN61000-3-3

DIMENSION and PHYSICAL CHARACTERISTICS		
Parameter	Type	Value
Material	case	plastic, (UL94V-0)
Unit Dimension (WxHxD)		45.1 x 92.0 x 101.2mm
Unit Weight		332g
Dimension Drawing (mm)		

continued on next page

Specifications (measured at $T_a = 25^\circ\text{C}$, 230VAC, full load and after warm up)

Dimension Drawing (mm)

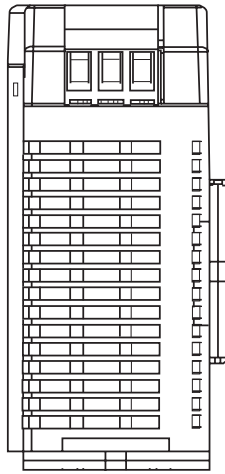

DIN-RAIL mounting bracket (75mm) included

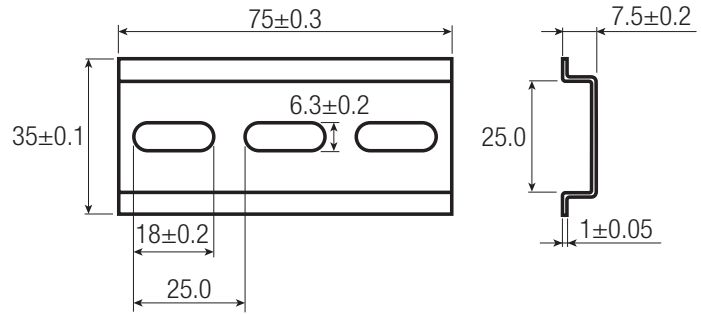

INSTALLATION

END MOUNTING

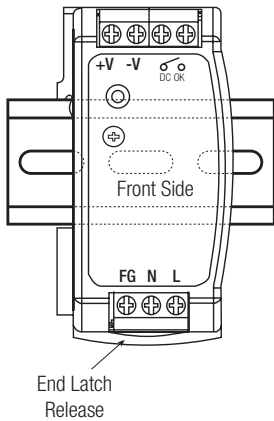

SIDE MOUNTING

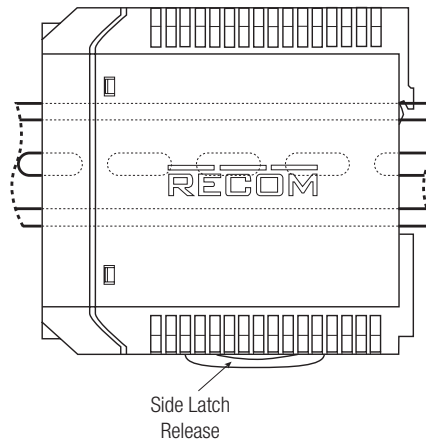

Mounting Instruction

Mounting

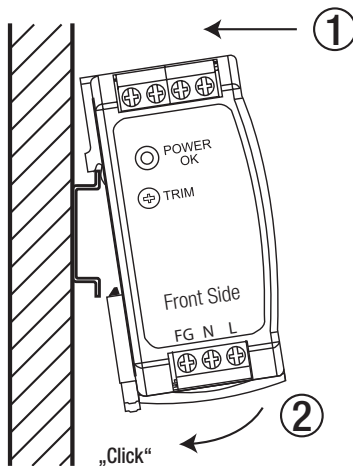

Releasing

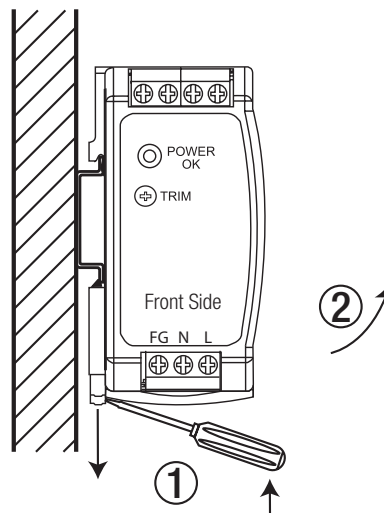

continued on next page

Specifications (measured at $T_a = 25^\circ\text{C}$, 230VAC, full load and after warm up)

Mounting Multiple Power Supplies

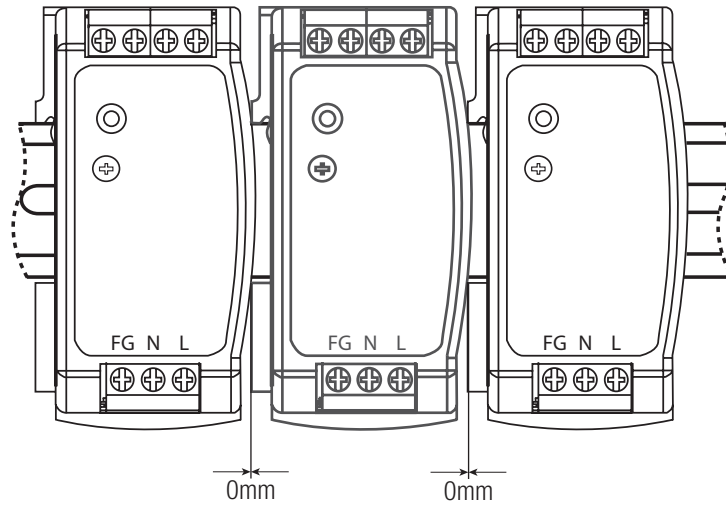

no spacers between supplies required
Kein Minimumabstand benötigt

BLOCK DIAGRAMM

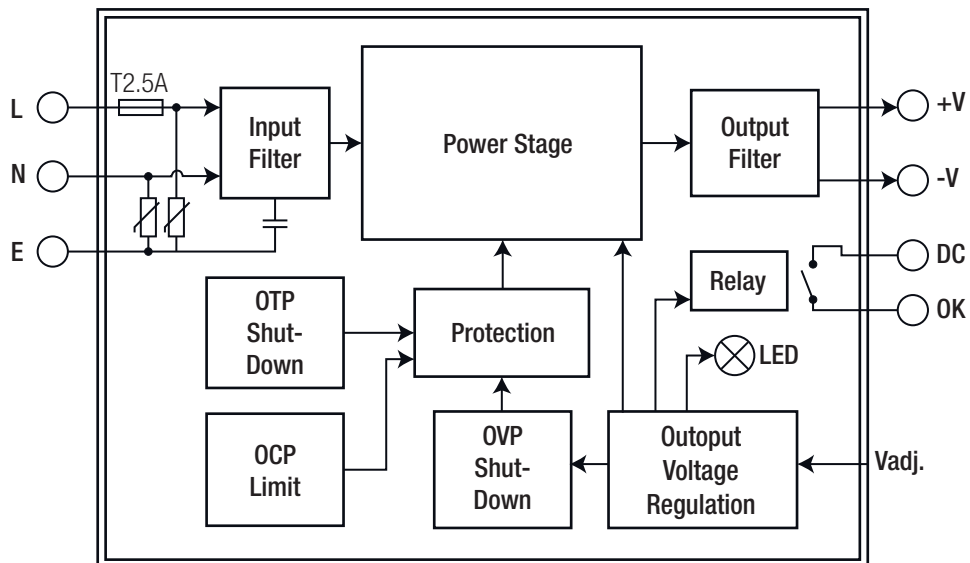

PACKAGING INFORMATION

Parameter	Type	Value
Packaging Dimension (LxWxH)	cardboard box	116.0 x 97.0 x 54.0mm
Packaging Quantity		1pcs
Storage Temperature Range		-30°C to +85°C
Storage Humidity		10% - 90% RH

The product information and specifications may be subject to changes even without prior written notice. The product has been designed for various applications; its suitability lies in the responsibility of each customer. The products are not authorized for use in safety-critical applications without RECOM's explicit written consent. A safety-critical application is an application where a failure may reasonably be expected to endanger or cause loss of life, inflict bodily harm or damage property. The applicant shall indemnify and hold harmless RECOM, its affiliated companies and its representatives against any damage claims in connection with the unauthorized use of RECOM products in such safety-critical applications.