

Features

Unregulated Converters

- High Isolation 2W Converter
- Approved for Medical Applications
- Custom Solutions Available
- 3kVDC and 4kVDC Isolation Options
- UL94V-0 Package Material
- Optional Continuous Short Circuit Protected
- Efficiency to 84%
- Suitable for IGBT Applications

Description The RKZ Series of 2W DC/DC Converters are certified to EN 60950-1 and to the medical standard EN-60601-1. This makes them suitable for high end industrial applications such as IGBT driver circuitry as well as standard medical applications. The RKZ converters are pin-compatible with the RK and RH converter series, offering a simple way to upgrade a 1W high isolation supply to 2W.

Selection Guide

Part Number	Input Voltage (VDC)	Output Voltage (VDC)	Output Current (mA)	Efficiency (%)	Max Capacitive Load ⁽¹⁾
RKZ-xx05S* (H)	5, 12, 24	5	400	82-84	1500µF
RKZ-xx12S* (H)	5, 12, 24	12	168	82-87	330µF
RKZ-xx15S* (H)	5, 12, 24	15	132	82-84	330µF
RKZ-xx05D* (H)	5, 12, 24	±5	±200	70-83	±680µF
RKZ-xx12D* (H)	5, 12, 24	±12	±84	82-84	±220µF
RKZ-xx15D* (H)	5, 12, 24	±15	±66	82-88	±220µF
RKZ-xx1509D* (H)	5, 12, 24	+15/-9	+67/-111	70-81	±330µF

xx = Input Voltage. Other input and output voltage combinations available on request.

* add Suffix "P" for Continuous Short Circuit Protection, e.g. RKZ-0515D/P,

* add Suffix „H" for 4kV Isolation, e.g. RKZ-0515D/HP has 4kV Isolation and is Short Circuit Protected.

Specifications (measured at T_A = 25°C, nominal input voltage, full load and after warm-up)

Input Voltage Range	±10%		
Output Voltage Accuracy	±5%		
Line Voltage Regulation	low line to high line @ 100% load	1.2%/1% of Vin typ.	
Load Voltage Regulation (10% to 100% load)	5V type	15% max.	
	Other types, RKZ-xx1509D	10% max.	
Output Ripple and Noise	20MHz limited	150mVp-p max.	
Operating Frequency	20kHz min. / 50kHz typ. / 85kHz max.		
	RKZ-xx1509D	20kHz min. / 51kHz typ.	
Efficiency at Full Load	70% min. / 80% typ.		
Minimum Load = 0%	Specifications valid for 10% minimum load only.		
Isolation Voltage	(tested for 1 second)	3000VDC	
	(rated for 1 minute**)	1500VAC / 60Hz	
Isolation Voltage	H-Suffix (tested for 1 second)	4000VDC	
	H-Suffix (rated for 1 minute**)	2000VAC / 60Hz	
Isolation Capacitance	120pF max.		
Isolation Resistance	10 GΩ min.		
Short Circuit Protection	only with „P"-Suffix	continuous	
Operating Temperature Range (free air convection, without derating)	-40°C to +85°C (see Graph)		
Storage Temperature Range	-55°C to +125°C		
Relative Humidity	5% - 95% RH		
Package Weight	2.8g		
Material	Case	UL94V-0, black plastic	
	Potting	UL94V-0, Epoxy	
Packing Quantity	25 pcs per Tube		
MTBF (+25°C)	Detailed Information see Application Notes chapter "MTBF"	using MIL-HDBK 217F	18300 x 10 ³ hours
(+85°C)		using MIL-HDBK 217F	8070 x 10 ³ hours

continued on next page

ECONOLINE

DC/DC-Converter

with 3 year Warranty

RECOM

2 Watt

SIP7

Single & Dual Output



EN-60950-1 Certified
IEC/EN-60601-1 Certified*
*** +15/-9 Version excluded**

RKZ

Derating-Graph (Ambient Temperature)

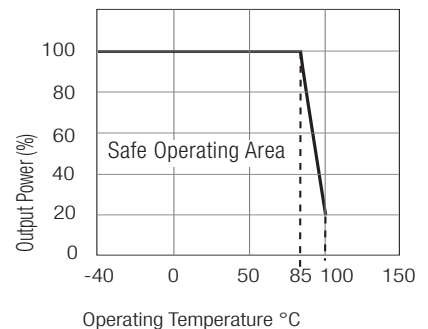

**Any data referred to in this datasheet are of indicative nature and based on our practical experience only. For further details, please refer to our Application Notes.



www.recom-power.com/eval-ref-boards

Specifications (measured at $T_A = 25^\circ\text{C}$, nominal input voltage, full load and after warm-up)

Certifications

EN General Safety
EN Medical safety

Report: SPCLVD1109103
Report: SPCMDD1205098-4

EN60950-1:2006 + A12:2011
IEC/EN 60601-1:2006, 3rd Edition

Notes

Note 1 Maximum capacitive load is defined as the capacitive load that will allow start up in under 1 second without damage to the converter.

Typical Characteristics

RKZ-xx05S

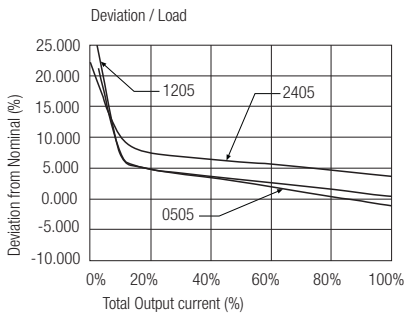
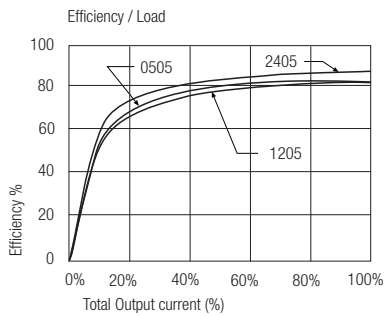

RKZ-xx12S

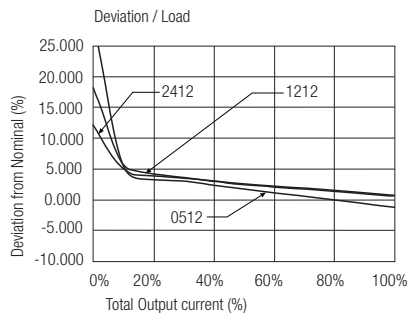
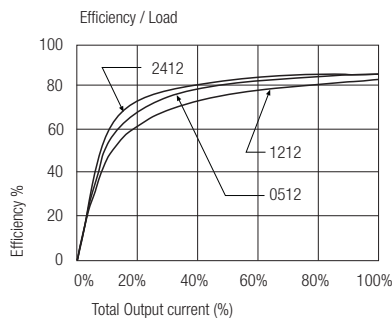

RKZ-xx15S

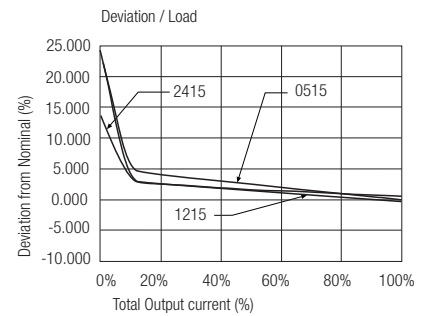
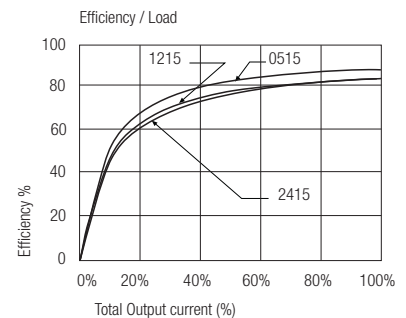

RKZ-xx05D

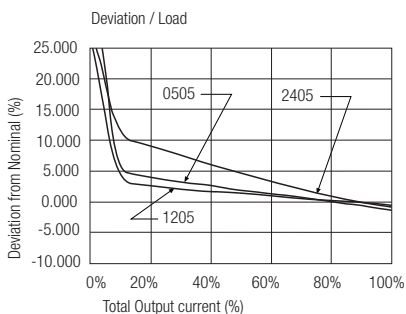
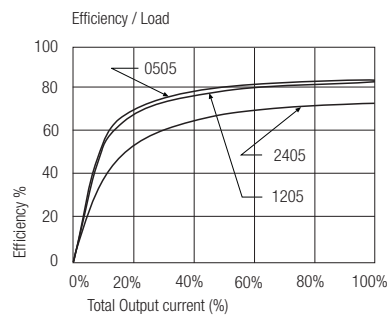

RKZ-xx12D

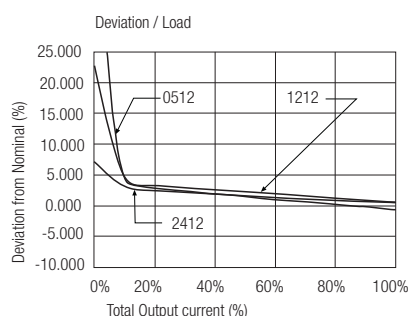
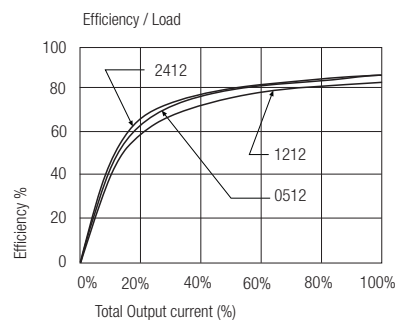

RKZ-xx15D

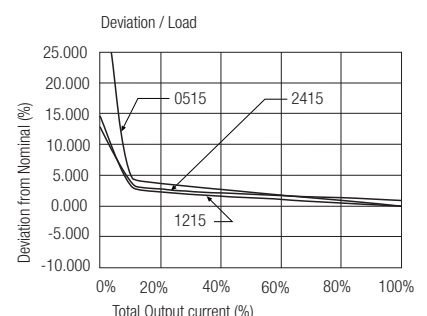
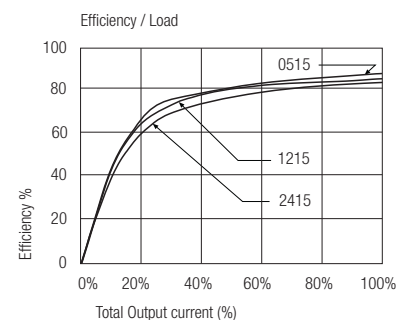

Application

IGBT Application Circuit

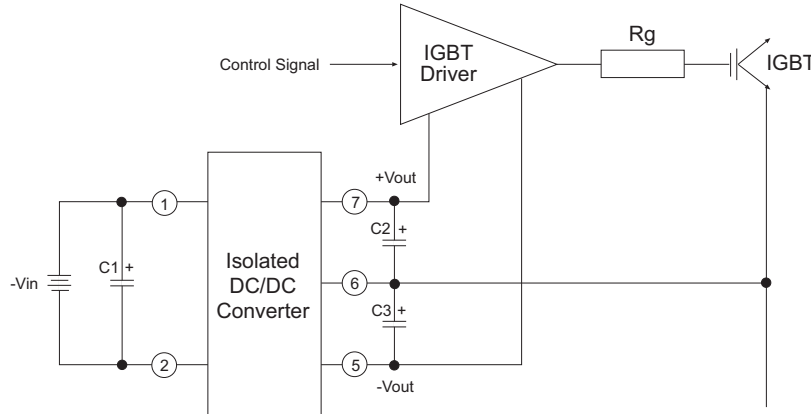

EMC Filter Suggestion for EN55022 Class B

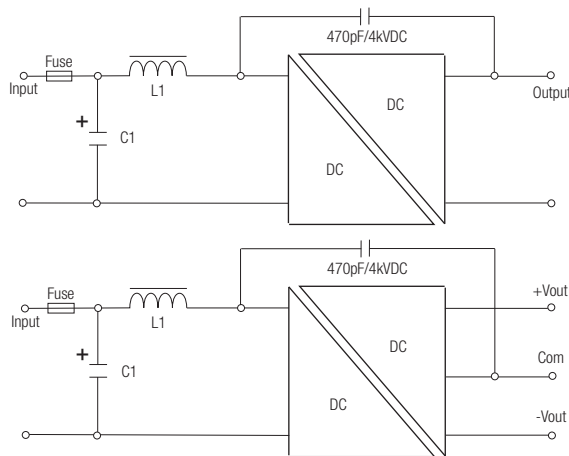

Standard and /H versions

C1	L1	Vin
10µF	4.7µH	5V
4.7µF	22µH	12V
2.2µF	47µH	24V

C1 = MLCC
L1 = SMD Inductor

Package Style and Pinning (mm)

7 PIN SIP Package

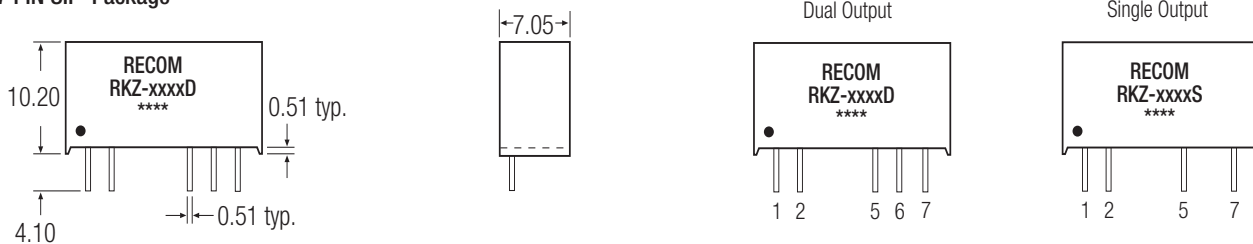

Recommended Footprint Details

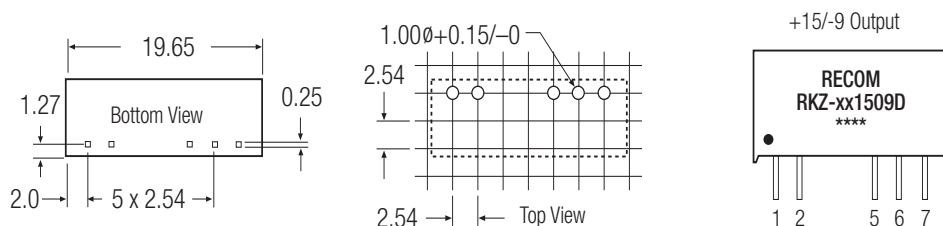

Pin Connections

Pin #	Single	Dual
1	+Vin	+Vin
2	-Vin	-Vin
5	-Vout	-Vout
6	No Pin	Com
7	+Vout	+Vout

NC = No Connection
XX.X ± 0.5 mm
XX.XX ± 0.25 mm

The product information and specifications may be subject to changes even without prior written notice. The product has been designed for various applications; its suitability lies in the responsibility of each customer. The products are not authorized for use in safety-critical applications without RECOM's explicit written consent. A safety-critical application is an application where a failure may reasonably be expected to endanger or cause loss of life, inflict bodily harm or damage property. The applicant shall indemnify and hold harmless RECOM, its affiliated companies and its representatives against any damage claims in connection with the unauthorized use of RECOM products in such safety-critical applications.